

Etched Glass M-4RD Reticle



VECTOR OPTICS

For More details please visit our website: www.vectoroptics.com

STORAGE
Avoid storing the riflescope in hot places, such as the passenger compartments of vehicles on hot days. The high temperatures could adversely affect the lubricants and sealants. A vehicle's trunk, a gun cabinet or a closet is preferable. Never leave the riflescope where direct sunlight can enter either the objective lens. Damage may result from the concentration (burning glass effect) of the sun's rays.

SEALING
The riflescope is nitrogen-purged to remove any vestige of internal moisture, also has O-ring to prevent the entry of dust or moisture.

MAINTENANCE
Your riflescope, though amazingly tough, is a precision instrument that deserves reasonable cautious care.

- When cleaning the lens, first blow away any dirt and dust, or use a soft lens brush. Fingerprints and lubricants can be wiped off with lens tissue, or a soft clean cotton cloth, moistened with lens cleaning fluid.
- All moving parts of the riflescope are permanently lubricated. Do not try to lubricate them.
- No maintenance is needed on the riflescope's outer surface, except to occasionally wipe off dirt or fingerprints with a soft cloth.
- Use lens covers whenever convenient.

BATTERY EXCHANGE
Your riflescope illumination is powered by 1 pc CR2032 button battery. Should the illumination grow dim or not turn on, you will need to exchange the battery. To exchange battery, use the proper screw driver to release the battery compartment cover. Remove the used battery, insert the new one. Screw on the cover again.

SEALED, WATERPROOF AND FOGPROOF
The riflescope is nitrogen-purged to remove any vestige of internal moisture, also has O-ring to prevent the entry of dust or moisture.

TURNING ON & ADJUSTING THE BRIGHTNESS LEVEL
Located on the left of the riflescope, controls the reticle illumination. There are 9 brightness level red illumination for Mustang 1-4x24FFP scope. Turning the knob will turn the illumination on. Simply turn the switch to adjust the brightness level of the reticle. Turn the dot scope switch will turn the red illumination on. The 1st level to the weakest and the 6th level to the brightest. Subsequently turn the dot scope switch will change the dot intensity. Set the switch to (0) will turn the unit off.

BATTERY EXCHANGE
Your riflescope illumination is powered by 1 pc CR2032 button battery. Should the illumination grow dim or not turn on, you will need to exchange the battery. To exchange battery, use the proper screw driver to release the battery compartment cover. Remove the used battery, insert the new one. Screw on the cover again.

Instruction for Vector Optics Mustang 1-4x24FFP Riflescope

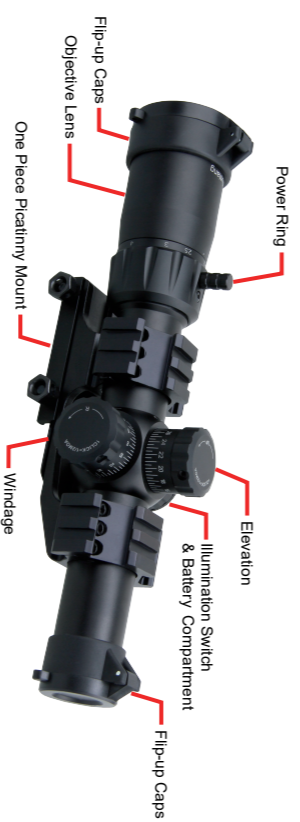

WARNING: NEVER LOOK AT THE SUN THROUGH THE RIFLESCOPE (OR ANY OTHER OPTICAL INSTRUMENT). IT MAY PERMANENTLY DAMAGE YOUR EYES.

EYEPiece FOCUSING
The eyepiece is designed to provide a precise fast focus at certain eye relief. The eyepiece will focus faster than your eye can compensate for any inaccuracy in your adjustment.

MOUNTING
The riflescope is installed on gun by means of one-piece weaver mount above. Use qualified mount with base designed to fit your particular rifle. The riflescope shall be mounted as low as possible without touching either the barrel or the receiver. For safety reasons, allow at least 3 inches of clearance between the riflescope and your eyes when shooting. Slide the riflescope forward or backward to acquire the proper eye relief that allows you to see full field of view. Rotate the riflescope in the rings that the vertical crosshair is vertical and horizontal crosshair is horizontal. Then tighten all screws to fix riflescope firmly on the rifle. Don't exceed 16 inch / pounds of torque on the ring's screws.

ZERONG
Mustang 1-4x24FFP scope features finger-adjustable audible-click elevation and windage adjustments. Elevation is the vertical (up-and-down) adjustment, usually on the top of the riflescope. Windage is the horizontal (left-to-right) adjustment, usually on the right of the riflescope. The scopes feature 1/2 MOA (Minute of Angle) windage and elevation adjustment with audible clicks, meaning that 1 click moves the point of impact 1/2 inch at 100 yards. With the riflescope mounted, rest the firearm onto a solid support and aim at a target 100 yards away. Slowly shoot a small 3 to 5 round test group onto your target. Adjust windage & elevation screws in the direction you want to move the bullet impact. Each click of adjustment moves the point of impact. Shoot another 3 to 5 round test group. Repeat until you are satisfied with the point of aim.

VARIABLE MAGNIFICATION ADJUSTMENTS
To change magnification, simply rotate the Power Selector Ring to achieve the designed power with index dot. Generally speaking, lowest power to have the widest field of view for quick shots at close range. Higher power should be reserved for precise long-range shots.